



**TELEDYNE LEEMAN LABS**  
Everywhere *you* look™



Simplicity



Reliability

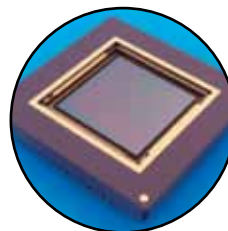

Performance

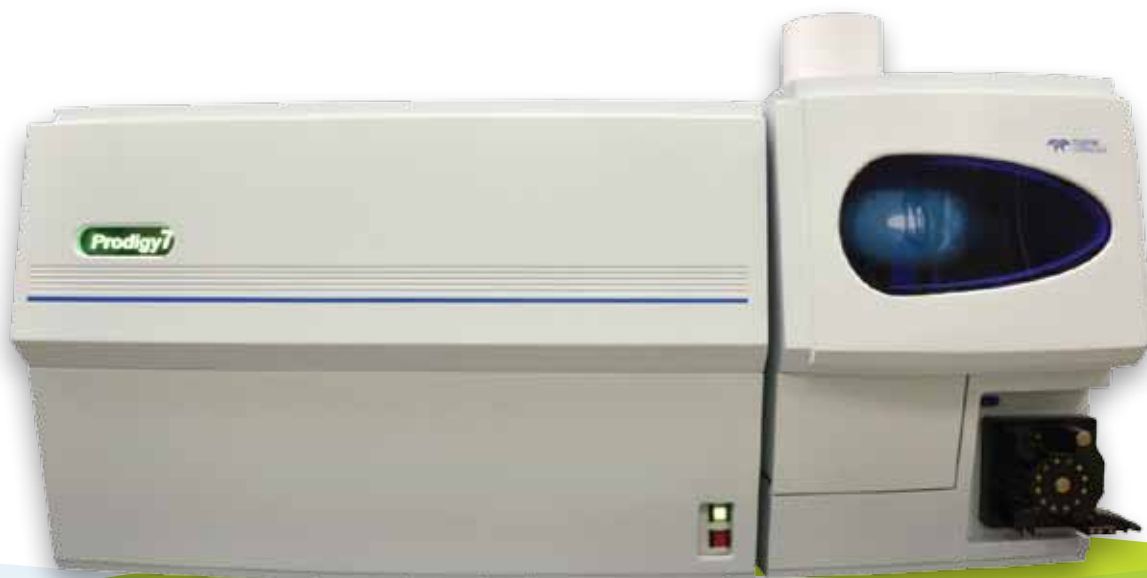

 **Prodigy7**

## ICP Without Compromise

At Teledyne Leeman Labs atomic spectroscopy is our business, our only business. We are deeply committed to providing you with technically superior products and the highly responsive support your needs to meet or exceed your own analytical requirements or those of your clients.

As capital equipment budgets continue to shrink, making sure any analytical instrument you purchase will provide the performance and capabilities required today as well as next month or next year has never been more important. Unfortunately, instrument manufacturers can make it difficult, if not impossible, for you to do so if the performance and capabilities you require today are provided by one particular instrument model but those you may need in the future are only available in another model and at a much higher price.

Teledyne Leeman Labs has taken a radically different approach with the Prodigy7. Through years of effort, our team of highly specialized engineers and application chemists have produced an ICP-OES instrument in which superior analytical performance does not have to be traded off for any reason including price. And while the Prodigy7 offers all of the advanced capabilities some laboratories require none of them have to be purchased upfront if not needed. They can be easily added later if needs change.

**Prodigy7: ICP without compromise.**



# Advantages of the Prodigy7

The Prodigy7 is the synthesis of advanced technology and user simplicity. The summation of years of refinement, the Prodigy7 has distinct advantages over other ICPs:

- Large format, advanced CMOS Array Detector for true simultaneous measurement
- Full wavelength coverage from 165 nm - 1100 nm
- 500 mm, Low Stray Light Optics (0.007 nm resolution @200 nm)
- *Full Spectral Access* (FSA) captures the entire wavelength spectrum in a single reading
- Available in Axial, Radial, and Dual-View configurations
- *Twist-n-Lock*, Auto-Aligning Sample Introduction System
- Compact benchtop design
- Designed for fast system startup and reduced gas consumption



## *Twist-n-Lock, Auto-Aligning Sample Introduction System*

The Prodigy7's thoroughly re-engineered sample system allows the operator to obtain consistent, high-quality results. The *Twist-n-Lock* allows adjustment of the sample system even while the plasma is running. The torch mount simply twists and locks into place, making leak-proof gas connections automatically, and returning the torch precisely to its optimum position.

***Consistent,  
high-quality  
results, first  
time and  
everytime.***





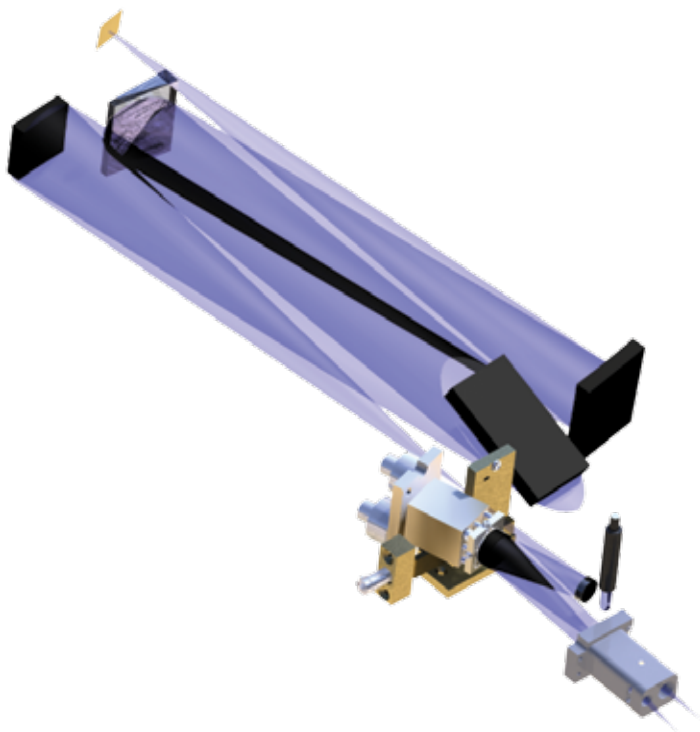

## High Energy, High Performance Optical System

A redesigned High-Energy, High-Resolution Optical System to complement its advanced CMOS Detector. The small internal volume reduces on purge gas consumption (1 L/min), while still providing the widest wavelength range of any ICP system available. With a focal length of 500 mm it provides a resolution of 0.007 nm @ 200 nm, and affords exceptional flexibility in wavelength selection. Because the entire Optical System is maintained at a constant temperature, its alignment has exceptional, long-term stability.

## State of the Art CMOS Detector

Cutting edge solid-state detector is designed specifically for ICP-OES, and exclusive only to the Prodigy7 ICP. The largest in the industry (28 mm x 28 mm) and containing 3.38 million pixels, the CMOS Detector is capable of capturing the entire ICP spectrum in a single exposure, at a speed 10x faster than older, less advanced devices. All of which means greater linearity, and the ability to determine the concentration of any element within a single full-frame acquisition. The CMOS Detector's unparalleled capabilities make it the new standard for ICP-OES.

The challenge creating any ICP method is choosing the proper wavelengths. Now with the combination of Prodigy7's broad wavelength range and powerful CMOS camera with *Full Spectral Access*, wavelengths can be selected quickly without any time consuming "trial and error." Why shouldn't you get the method right the first time? With Prodigy7 you will.

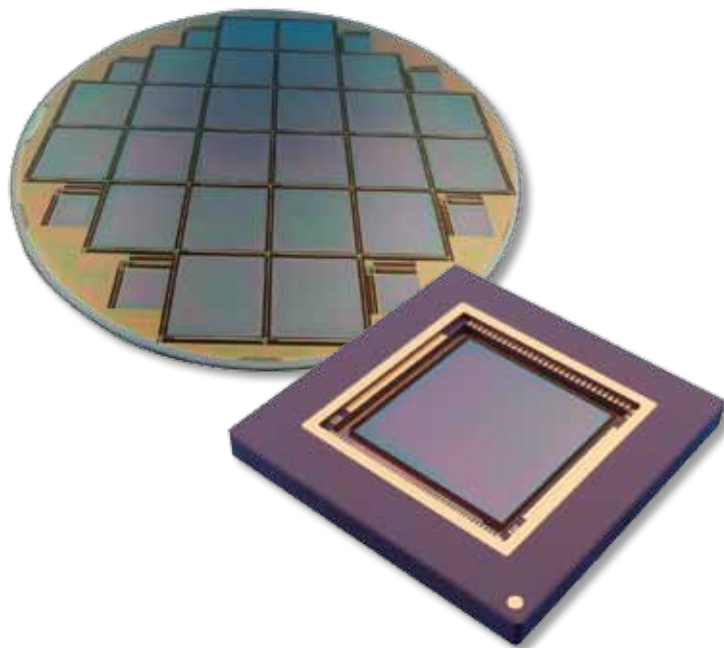

*Prodigy7: ICP without compromise.*



#### High Resolution Echelle Optical System

Provides complete wavelength coverage from 165 to 1100 nm with the resolution required to minimize interferences. Temperature controlled to provide long-term stability. Its small volume reduces purge gas (Nitrogen or Argon) consumption.

#### Advanced CMOS Detector

A true simultaneous, high-speed device. *Full Spectral Access (FSA)* captures the entire spectrum in a single reading, at high resolution, using 3.38 million pixels. FSA makes the identification of any element present possible within a single analysis, saving time and eliminating duplicate analyses.

#### 40.68 MHz Free-Running Power Supply

Aqueous, high-solids and organic samples are easily analyzed with a powerful, field-proven design.



## Report with Confidence

Prodigy7 consistently delivers measurements with the accuracy and precision you require and your clients demand. Results supported with instrumental conditions verification, validation of calculations used and backed with tamper proof storage.



#### Venting

No special venting required. No more than 100 ft<sup>3</sup>/min (or 2.8 m<sup>3</sup>) is needed regardless of plasma configuration.

#### Radial, Axial or Dual View

The "right" view for any sample type or elemental concentration. Choose the view that best suits your needs.

#### Twist-n-Lock, Auto-Aligning Sample Introduction System

Simplifies day-to-day operation and allows all operators, regardless of skill level, to consistently obtain the highest quality results. Configurable with novel demountable "hybrid" torches for significantly reduced argon consumption compared to conventional systems.

#### Image Stabilized Plasma

Directly coupling the torch to the Optical System means extended stability, faster system startup and improved productivity.

#### 4-Channel Peristaltic Pump

Provides the flexibility required for Hydride Generation and on-line addition of internal standards.



**Prodigy7: ICP without compromise.**



# Prodigy7 Software

ICP's are analytical workhorses, capable of systematically running large quantities of samples according to a preset "Method" of analysis. ICP analysis generally follows these four simple procedures:

1. Select a "Method" (Choose Method)
2. Place samples into the autosampler (Prepare the Sequence)
3. Analyze the samples (Start the Sequence)
4. Report the data (Report the Data)

It only makes sense that ICP instrument software should make running samples easy. This is why our engineering team has consistently embraced a no-nonsense philosophy to software design. Through the use of highly intuitive graphics and an uncluttered user interface, Prodigy7 operators get to all of their tasks quickly and efficiently, without navigating through complex screens and menus.

However, for those who need to conduct 'advanced tasks' Prodigy7's software makes doing so very straightforward.

- Create a unique method tailored to specific analytical requirements
- Fine tune an existing method to achieve superior analysis results for a challenging sample type
- Perform a highly detailed review of results for a specific sample or series of samples
- Take advantage of the 'Full Spectral Access' (FSA) capability to determine the concentration of components not targeted in the original analysis
- Perform 'Time Resolved Analysis' (TRA)

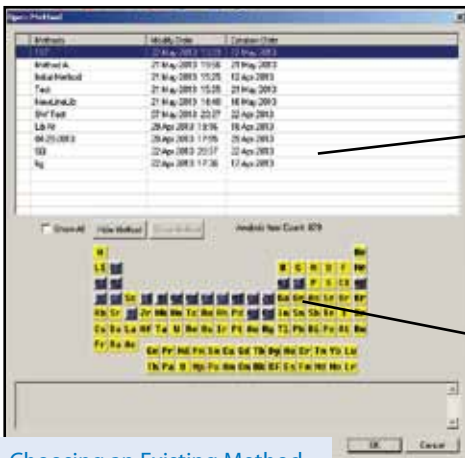

A selection of methods are displayed in the "Open Method" Dialog.

Elements included in each Method are easily identified on a Periodic Table.

Choosing an Existing Method

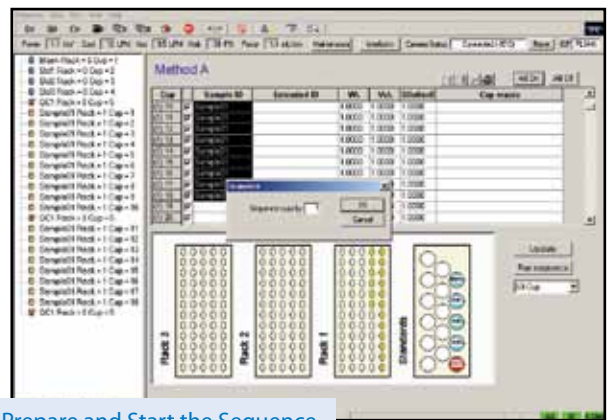

Prepare and Start the Sequence

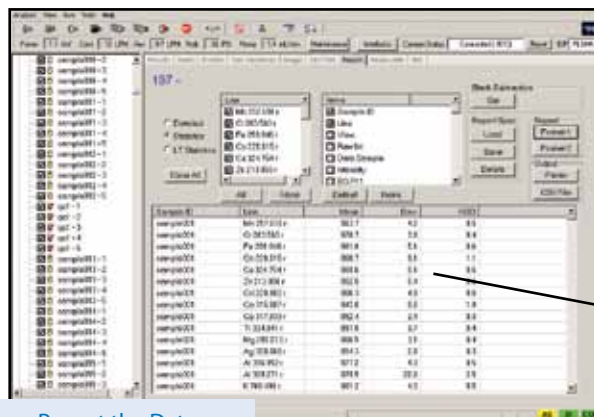

Report the Data

Export Reports to LIMS or other remote locations directly, in the format desired.





## Quantitative Full Frame Feature

The Prodigy7 offers the operator the unprecedented capability to immediately determine the concentration of any element in a sample without having the element in a method itself. This is only possible with the new, high speed CMOS detector.

Take a full frame image and click the "QA" button.

Read the concentrations.

Element	wave#	Conc
Phosphorus	413.618	98.1
Lithium	220.353	94.1
Sulfur	182.034	90.4
Selenium	196.090	80.6
Arsenic	193.759	72.7
Aluminum	396.152	28.5
Antimony	206.833	5.1
Sodium	589.592	3.1
Diarsenic	353.170	2.3
Tungsten	207.911	1.3
Rhodium	343.489	1.2
Calcium	317.593	1.0
Tellurium	214.201	0.8
Niobium	309.418	0.7
Tantalum	226.230	0.5
Silicon	251.511	0.4
Cerium	413.765	0.1
Iridium	224.268	0.1
Samarium	359.260	0.1
Potassium	766.491	0.1
Fibrem	337.771	0.0

*It's that easy!*

*Prodigy7: ICP without compromise.*

## Accessories

### Autosamplers

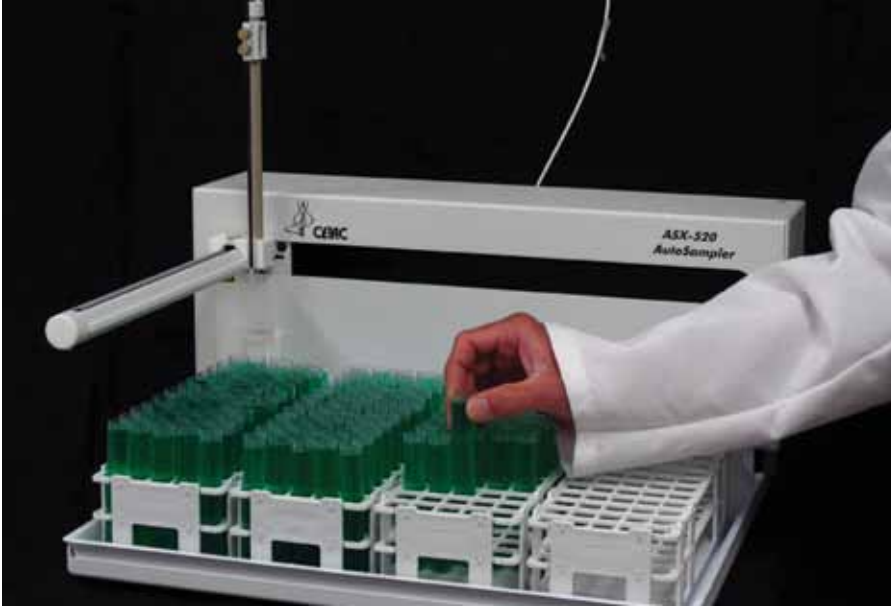

Everyone's day to day needs differ. Some labs only need to analyze a few samples per day while some must analyze dozens and dozens. Some labs analyze the same samples types over and over while others must be prepared to analyze a very wide variety.

Leeman Labs recognizes this and offers a full range accessories and consumables all designed and optimized to maximize your Prodigy7 experience. These include Teledyne CETAC autosamplers, application specific nebulizers, spray chambers and specialized torch assemblies.

### Nebulizers and Spraychambers

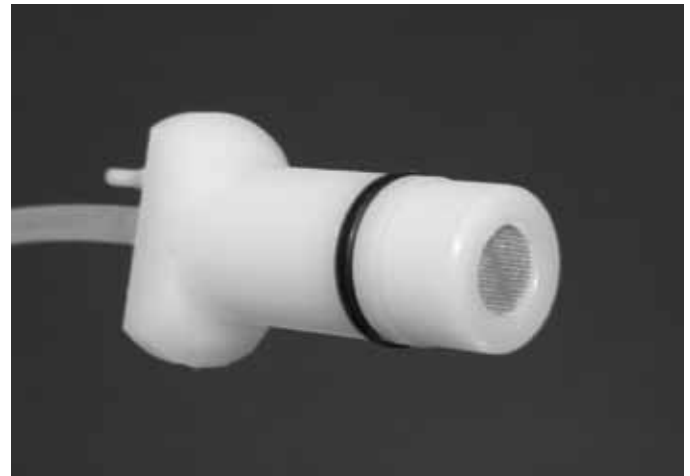

## Leeman Labs and Elemental Analysis

Our experience isn't limited to ICP-OES alone. It extends to a variety of Atomic Spectroscopy analysis techniques, with the same quality, precision, functionality and thorough engineering we've built our reputation on. If you're seeking elemental analysis for your specific application or industry, Teledyne Leeman Labs is the solution.

### DC Arc Spectrometer

Our DC Arc Spectrometers are the ultimate solution for elemental analysis of the most challenging solid samples. The DC Arc can perform elemental analysis on samples that are difficult or nearly impossible to digest, or samples in their native form without digestion.

### Mercury (Hg) Analyzers

Our Mercury (Hg) Analyzers meet regulatory demands for measurement of Hg in solid, semi-solids and liquid samples accurately and efficiently.

25

26  
Fe

27  
Co

28  
Ni

29  
Cu

30  
Zn

# System Specifications

Prodigy7 Specifications			
Optical Design	High Energy Echelle Polychromator	Detector Type	CMOS
Focal Length	500 mm	Size	28 mm x 28 mm
Dispersion	0.1 nm/mm @ 200 nm	Number of Pixels	3.38 million (1840 x 1840)
Optical Resolution	0.007 nm @ 200 nm	Pixel Size	15 $\mu$ m
Pixel Resolution	0.0015 nm@ 200 nm	Active Area	100%
Wavelength Range	165 - 1100 nm	Measurement Mode	Simultaneous

Site Planning Information	
Length	48.0 in (1220 mm)
Depth	27 in (682 mm)
Height	27.5 in (698 mm)
Weight	231 lbs (105 Kg)
Shipping Weight	445 lb (202 Kg)
Electrical	Grounded Single-Phase Power Supply 190-230 V, 30 A, 50/60 Hz
Exhaust Venting	100 ft <sup>3</sup> /min (2.83 m <sup>3</sup> /min)

